

Safe Guard II – ILDA Version

Scanner-safety board

Functions:

The safety board measures the inputs:

- X and Y of the Galvo-feedback signals
- X and Y from the computer for unsafe signals

For this reason the signals are measured at 8bits resolution with the onboard micro-controller. Two different main functions are included:

1. Detection of movement speed

All signals have to track a pre-selected distance within the safety time of 50ms to switch on the laser beam. This distance can be adjusted via the hysteresis pot. If one of the signals (computer input or feedback input) fails to track the pre-selected distance the laser beam will shut down. The time window is 50ms. Since safety officers recommend to have at least 100ms detection time we decided to enhance this time to 50ms.

So the switching criteria are:

- Movement X input AND feedback X OR movement Y AND feedback Y = Laser ON.
- All other conditions: Laser off.
- At least one axis has to be in safe condition.

2. Safe Area Window (SAW)

If some users shoot beams to external mirrors then both axis have to hold a static standing condition. If the safety window isn't changed, the laser will be switched off. (Board detects unsafe condition, tracking distance too short). For this reason the SAFE-GUARD II board has an adjustable safety area

Each axis can have a safe area (space above audience / area within a screen / projection on wall), which is fully adjustable.

The detection of this area verifies the input signal, the feedback signal and the position to detect an unsafe condition within the safety area. The tolerance between input signal and feedback signal is 10%. The board needs to have this tolerance for existing phase shifting between computer and feedback.

Jumpers for mode

There are three different running modes:

- Standard
- Inverted
- AND combination
- Test

In the standard mode the function is as described earlier. With the invert jumper it is possible to invert the safe are if windows are selected.

The AND mode allows the user to combine both X and Y safety functions. In normal mode one axis can be defective or stay in one position. Only if both axes have an unsafe condition the output shuts down. In the AND mode the output shuts if **one of both** axes have an unsafe condition.

The test mode is for adjustment.

Jumpers for signal inverting

Some driver boards have a signal inverting onboard which turns the input signal onboard. Thus the feedback signal is inverted against the computer signal. In this case invert the input signal for the safety board.

Adjustments for input signal

The input signals have to be at the same level. To adjust this you need an oscilloscope which should be connected to Pin 13,14,15 & 16 of the CPU (be aware of shorts!). All signals there should have the same amplitude within 10% tolerance of approx 0-5V DC.

IMPORTANT: The input signal adjustment is only needed for the SAW, not for the scanner safety function! A wrong setup influences NOT the safety detection!

Adjust hysteresis

- Adjust all jumpers
- Scan biggest possible line
- Adjust hysteresis until you see the full line
- Scan 50% of the full line
- Adjust hysteresis until you see the line
- Scan biggest permitted line for sage audience scanning (measure with power meter)
- Adjust hysteresis until you see the line
- If you decrease line size, the output should shut down

Adjust SAW

Set test jumper.

Scan test grid over the full scanning area with the slowest possible scanning speed.

You should see now the bars within the unsafe area. If there is full SAW area selected, you will see nothing. The default-mode after factory shipment is full SAW.

Adjust your SAW area with the pots.

All unsafe areas will be visible!

This means, within the visible areas there is no tracking time detection. After removing the test jumper the SAW compares to the adjustments in the test mode.

After adjusting the SAW area, remove the test jumper

Inverting SAW

To allow all possible combinations the safety area can be inverted from inside to outside.

Technical Data:

Source:	+/- 18VDC to +/- 30VDC from scanner source
Sample rate:	5.000 per second (<200µs sampling time)
Detection time:	50ms
Switch off time:	200ms - 250ms min. (eyelid reflex)
Processing speed:	16 MHz
Delay at shut down:	<50µs
Safety output:	Active high

Plus:

- Watchdog for processor failures.
- Potential free blanking output

Power Connection

The SAFE-GUARD II board requires +18V to +30VDC, GND and -18V to -30VDC power supply. Please use the same power supply that you use for your scanner driver to supply voltage to the safety board.

How to connect the SAFE-GUARD II board to your CATWEAZLE LC II Board

Use the solder balls at the bottom side of the condensers as indicated on the photo.

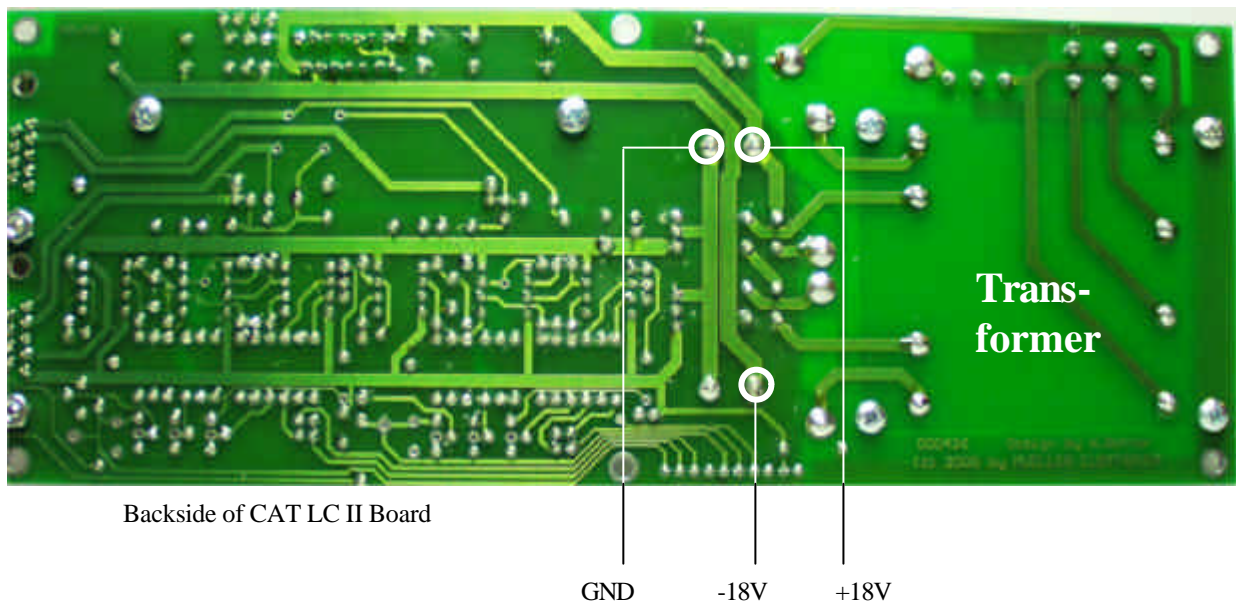

Connection of signal voltage

Symmetric Signals

If you use the symmetric signals +X / -X and +Y / -Y respectively, only connect the positive signals to the SAFE-GUARD II board. Connect the negative signals directly at the scanner driver.

Asymmetric Signals

If you use the symmetric signals +X / GND and +Y / GND respectively, connect the positive signals to the SAFE-GUARD II board.

Board-Layout / Connections

ILDA Board Layout:

White Connector Slot, 10 pins, Connection equivalent to CAT LC II.

Connect the blanking signal to the White connector, 2 pins.

